

# Heavy Duty DC Battery Disconnecting Switches

SD 150 A & SD 250 A TYPES  
ED 125, ED 250, ED 252 &  
ED 402 TYPES



ED 125



SD 150 LA



SD 250 A



ED 250 A

*Albright*

INTERNATIONAL

## Heavy Duty DC Battery Disconnecting Switches

### The Use of Battery Disconnecting Switches in Electric Vehicles

Modern battery powered electric vehicles are inherently very reliable and safe but even when sophisticated electronic controllers are used it is desirable to have a means of disconnecting the battery in the event of an emergency, such as a vehicle failing to stop, or an electrical short circuit.

Indeed in many countries it is mandatory to fit one or more devices to achieve an emergency disconnection of the battery.

*The options are as follows:*

- 1) Manual disconnecting switches such as the Albright "SD" and "ED" devices.
- 2) A minimum of two contactors with their contacts in series. This usually means a main line contactor and an additional contactor for each major electrical circuit.
- 3) A battery plug, providing this is within easy reach of the vehicle driver.

Other practical considerations are the need to make the vehicle electrically "Dead" with a keyswitch when not in use and the ability to isolate the battery during routine maintenance.

The most cost effective means of achieving all safety, legal and practical requirements is the Albright "SD" combined manual and electrical disconnecting switches as described in this leaflet.

Alternatively a manual disconnecting switch such as an Albright "ED" (also described in this leaflet), together with a separate line contactor is also worth consideration.

Please see also the Albright publication "Line Contactors for Electric Vehicles".

The "SD" & "ED" ranges of disconnecting switches have been designed to provide a rapid means of disconnecting batteries or other power supplies in the event of serious electrical faults.

The switches are primarily intended for use with battery powered vehicles but are also suitable for use with static power systems. All types are capable of safely rupturing full load battery currents in the event of an emergency.

TYPE NO.	DESCRIPTION	THERMAL CURRENT RATING (100%)
<b>SD150A</b>	Combined Manual Disconnect & Line Contactor - Single Pole On/Off	125 Amperes
<b>SD150AL</b>	With Lock	
<b>SD250A</b>	Combined Manual Disconnect & Line Contactor - Single Pole On/Off	250 Amperes
<b>SD250AL</b>	With Lock	
<b>ED125</b>	Manual Disconnect Single Pole On/Off	125 Amperes
<b>ED125L</b>	With Lock	
<b>ED250</b>	Manual Disconnect Single Pole On/Off	250 Amperes
<b>ED250L</b>	With Lock	
<b>ED252</b>	Manual Disconnect Double Pole On/Off	250 Amperes
<b>ED252L</b>	With Lock	
<b>ED402</b>	Manual Disconnect Double Pole On/Off	400 Amperes
<b>ED402L</b>	With Lock	



SD150LA

### Explanation of Type Numbers

ED125 - L - A - B - 3

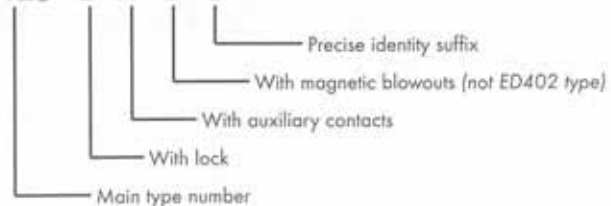

# SD150A & SD250A TYPES COMBINED MANUAL DISCONNECT & LINE CONTACTORS



SD150A

These switches combine the dual function of a manual disconnect and coil operated line contactor. The benefits of this design include compact size and reduced installation costs combined with an electrical capacity sufficient for most small and medium size electric vehicles.

## Modes of Operation

The operation of the SD150A & SD250A switches is such that with the operating knob depressed i.e. in the "Off" position, no electrical functions can take place. However if the knob is in the "On" position, the option of energising the coil and thus closing the main contacts becomes available. The coil energisation can be carried out either through the vehicle keyswitch or as a result of a signal from the vehicle electronic controller.

When the SD150A & SD250A switches are used as an emergency battery disconnecting switch, manually depressing the operating knob will override the energised coil such that the main contact and the auxiliary contact will open until such time as the knob is again moved to the "On" position.

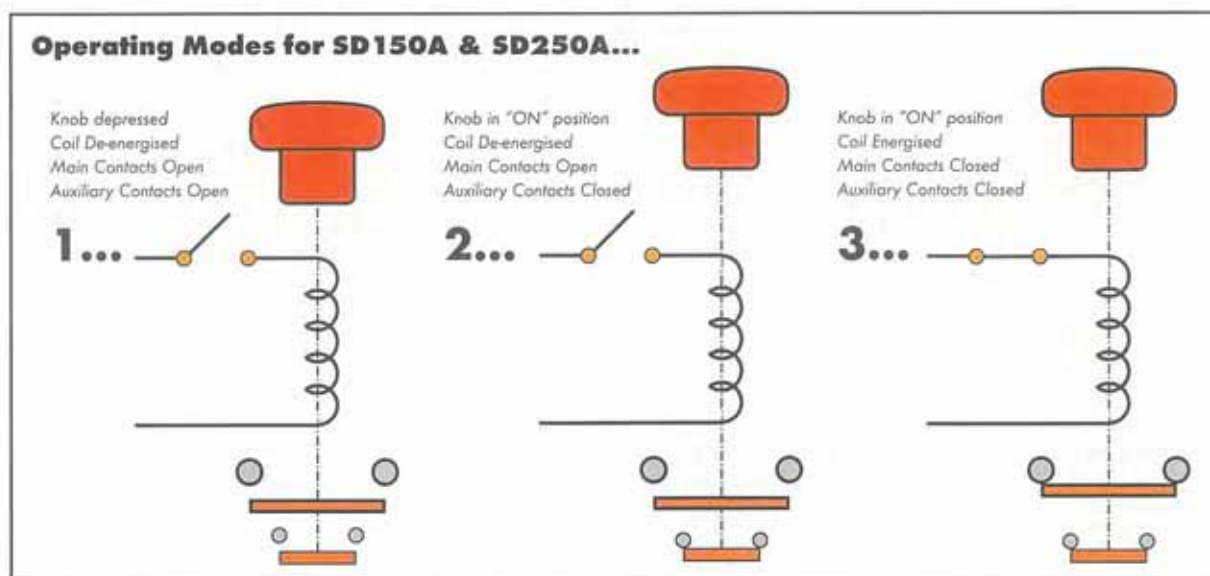

## Operating Coils

These are normally continuously rated, although intermittently rated versions are also available.

## Auxiliary Contacts

An integral auxiliary contact is fitted to the SD150A & SD250A. This has one normally open contact which closes when the knob is put into the "On" position.

The status of the auxiliary contact on the SD150A & SD250A switches is not affected by the energisation or de-energisation of the coil.

An additional double circuit normally open, normally closed changeover auxiliary contact can be fitted to the SD150A & SD250A switches.

The suffix "A" indicates the fitting of auxiliary contacts.

**Heavy Duty  
DC Battery  
Disconnecting  
Switches from...**

*Albright*  
INTERNATIONAL

**SD 150 A**  
125 AMPERE  
SINGLE POLE

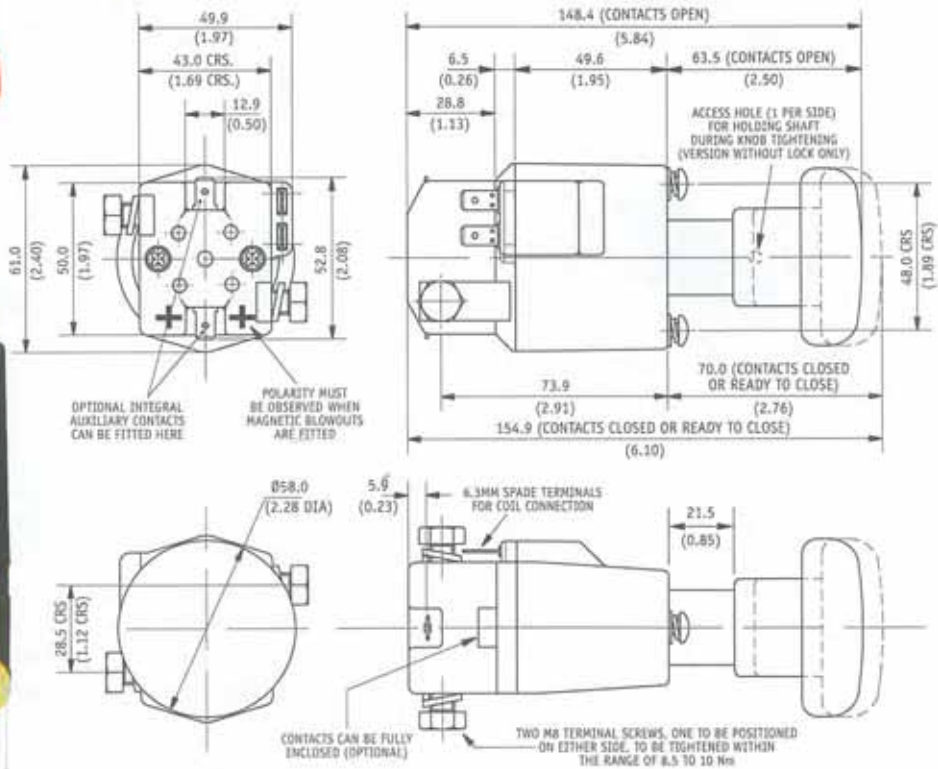

**SD 250 A**  
250 AMPERE  
SINGLE POLE

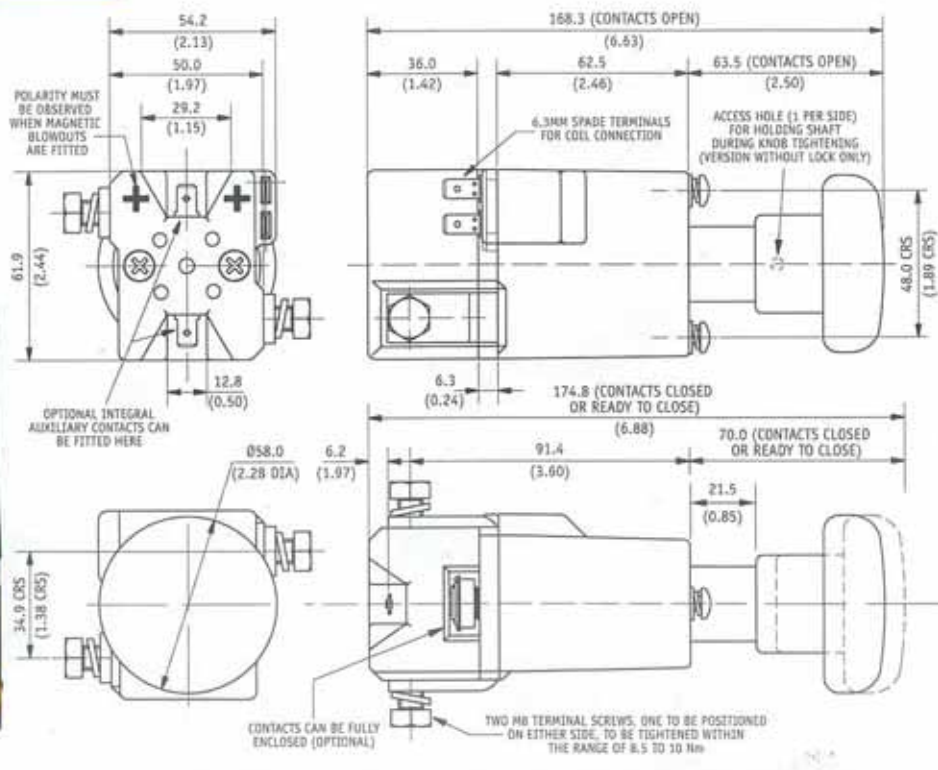

# ED 125, ED 250, ED 252 & ED 402 TYPES MANUAL DISCONNECT SWITCHES

These switches are manually operated devices with a simple over-centre spring mechanism which provides a "Snap Action" for both opening and closing of the main contacts.

## Modes of Operation

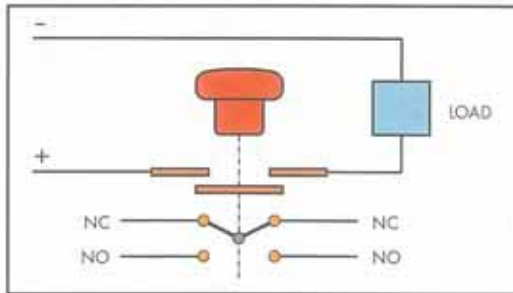

Simply pulling the operating knob upward closes the main contacts and depressing the operating knob opens them again.

Electrical schematic for ED125A & ED250A



**Heavy Duty  
DC Battery  
Disconnecting  
Switches from...**

*Albright*  
INTERNATIONAL

## Auxiliary Contacts

A double circuit normally open, normally closed microswitch auxiliary contact can be fitted. This has a D.C. resistive rating of 15 amperes at 24 volts.

The auxiliary contact can be set to operate either before or after the main contacts open, according to the circuit requirements. Unless otherwise specified the auxiliary contact will be set to operate in advance of the main contacts opening.

The suffix "A" indicates the fitting of auxiliary contacts.

ED 125  
125 AMPERE  
SINGLE POLE



See Page 7 for mounting details.

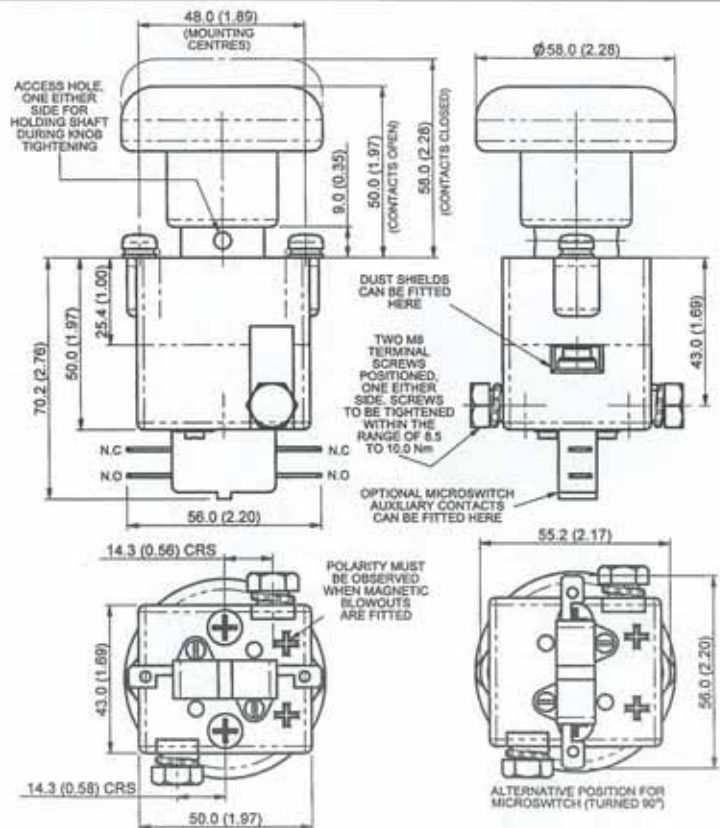

**ED 250 /  
ED 252  
250 AMPERE  
SINGLE /  
DOUBLE  
POLE**

Dimensions in mm (inches). See Page 7 for mounting details.



ED252A

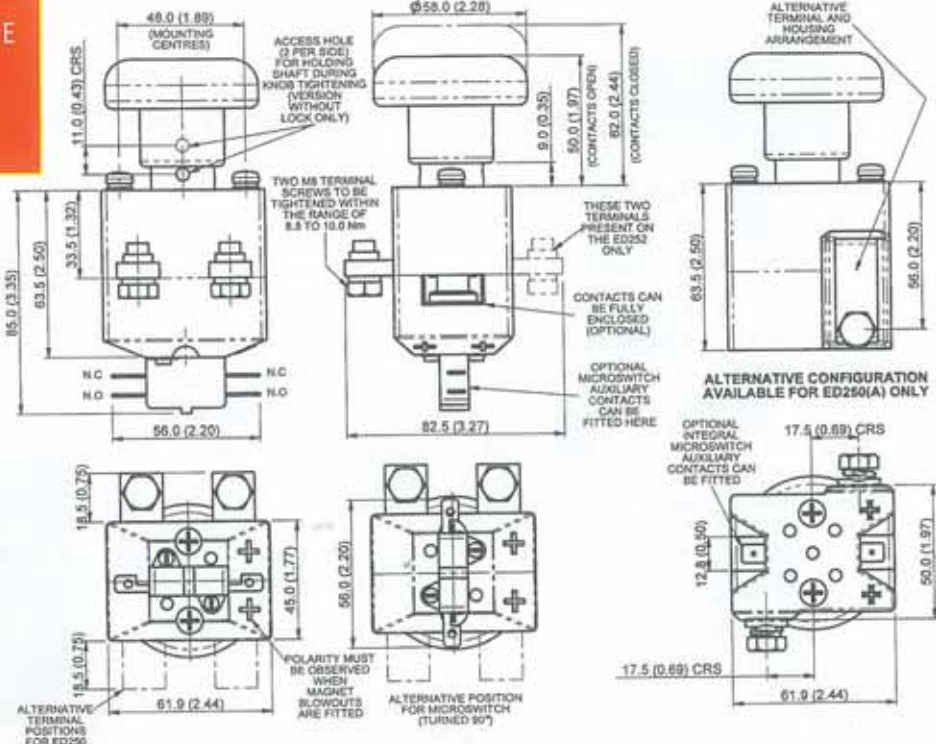

**ED 402  
400 AMPERE  
DOUBLE POLE**

Dimensions in mm (inches). See Page 7 for mounting details.

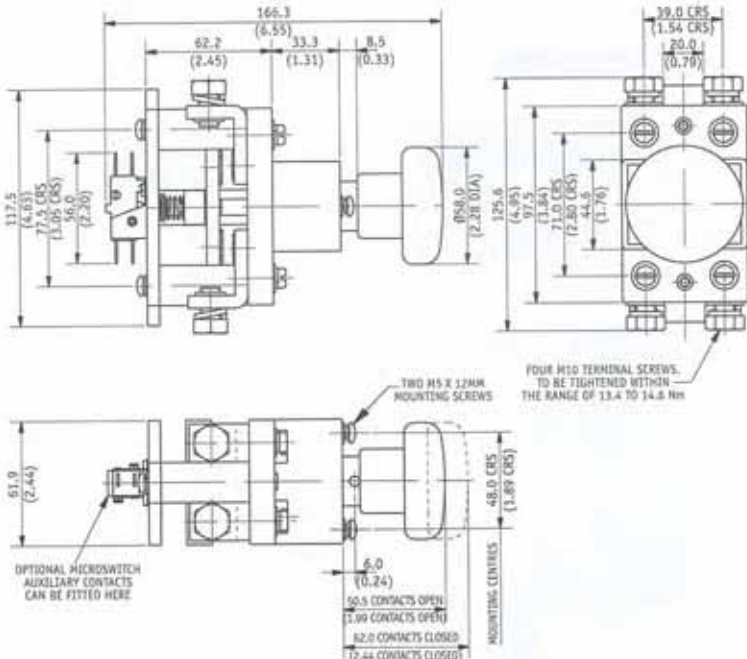

**Heavy Duty  
DC Battery  
Disconnecting  
Switches from...**



Electrical schematic for ED252A & ED402A

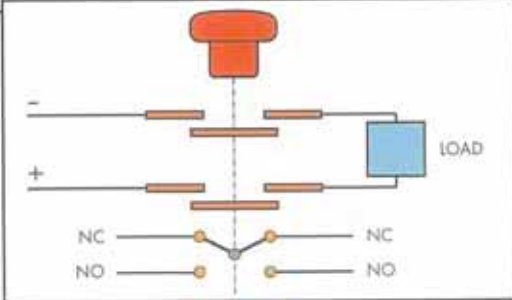

# COMMON FEATURES ON SD & ED SWITCHES

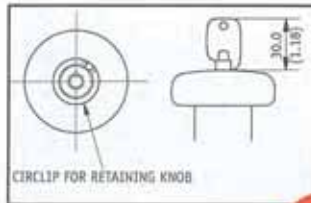

Lock details



SD150LA

A number of features are common to both the SD150A & SD250A switches and the ED125, ED250, ED252 & ED402 switches.

## Heavy Duty Contacts

The switches all have double breaking main contacts with silver alloy contact tips which are weld resistant, hard wearing and have excellent conductivity.

## Lockable Version

Lockable versions of both the "SD" & "ED" switches are available. For these versions a key is necessary for the knob to be moved from the "Off" position to the "On" position. Once in the "On" position, the key can be removed. Thereafter, the knob may be depressed to the "Off" position where it will automatically lock and remain locked until the key is used again to unlock it. *The suffix "L" applies for lockable versions*

## Protection

Optional barriers can be fitted into the contact housing of all versions of the "SD" & "ED" switches, except for type ED402. These should be specified when the switches are to be used in environments where there is airborne contamination.

## Magnetic Blowouts

All versions of the "SD" & "ED" switches can be fitted with magnetic blowouts, except for type ED402. These are permanent magnets situated across the contact gaps and they greatly enhance the arc rupturing capability of the switches. *The suffix "B" indicates the fitting of magnetic blowouts.*

## Easy Installation

Mounting is by means of two 5mm screws and details of the fixing centres are shown in the diagram.

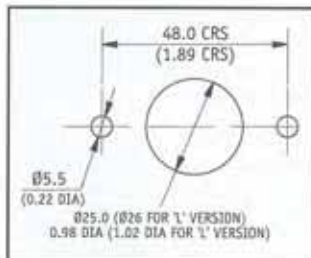

Mounting Details  
for all types

## Serviceability

Both ranges are fully serviceable with replacement contacts being readily available.

For the standard versions (without lock) operating knobs are affixed by an 8mm thread and for the lockable versions knobs are retained by a circlip.

## Precautions

NOTE: For single pole types fitted with magnetic blowouts (SD150AB, SD250AB, ED125B & ED250B), the polarity marked on the contact housing must be observed when connecting the main terminals.

Ensure that the switches are installed in a position where heavy arcs emanating from the switch cannot damage or electrically jump across to adjacent parts.

For the standard versions (without lock) ensure that the knob is fully tightened. A 4mm hole in the tubular shaft housing allows a bar to be inserted which will prevent the shaft from turning during knob tightening.

The "SD" & "ED" switches are to be used to rupture current in an emergency or as a "No Load" isolator. **DO NOT USE THEM AS REGULAR "ON LOAD" SWITCHING DEVICES.**

No regular maintenance is necessary but in the event of an emergency switching the switches should be inspected and checked for correct operation and if necessary change the contacts before putting back into service.

# PERFORMANCE DATA FOR ALL SWITCHES

## Contact Performance (intermittent ratings)

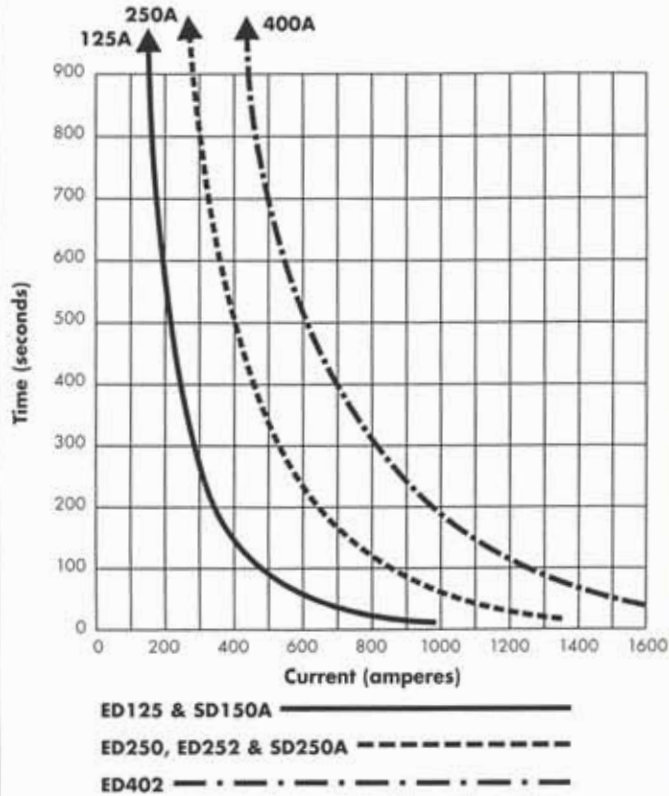

## Max. Recommended Contact Voltages:

ED125, ED250, SD150A & SD250A:	48V DC
ED125B, ED250B, SD150AB & SD250AB:	96V DC
ED252 & ED402:	96V DC
ED252B:	150V DC

## Overload Currents that can be Ruptured

ED125/SD150A:	800 Amperes at 48V DC
ED250/SD250A:	1000 Amperes at 48V DC
ED252:	1500 Amperes at 48V DC
ED402:	1500 Amperes at 48V DC
ED125B/SD150AB:	800 Amperes at 80V DC
ED250B/SD250AB:	1000 Amperes at 96V DC
ED252B:	1500 Amperes at 96V DC
ED402:	1000 Amperes at 96V DC

## Typical Voltage Drop across contacts per 100 Amperes (per Pole):

ED125/ED252/SD150A:	40mV
ED250/ED402/SD250A:	30mV

## Mechanical Life:

Manually Operated (All Switches):	>10,000
Electrically Operated ("SD" Switches Only):	>3,000,000

## Coil Power Dissipation:

Continuously Rated Types ("SD" Switches Only):	
SD150A:	7-13
SD250A:	10-15

## Maximum Pull-in Voltage (Coil at 20°C):

Continuously Rated Types ("SD" Switches Only):	66%V
--	------

## Typical Drop-out Voltage:

SD150A & SD250A Only:	10-30%
-----------------------	--------

## Weights

Contactors Type No.	Weight (grams)
ED125	300
ED250	450
ED252	520
ED402	1000
SD150A	550
SD250A	870

**NOTE:** Add 20 grams for additional Auxiliary Contacts.  
Add 60 grams for a Lock.  
Add 50 grams for Magnetic Blowouts.

## Typical Pull-in time (n/o contacts to close):

SD150A & SD250A Only: 20ms

## Typical Drop-out time (n/o contacts to open):

SD150A & SD250A Only:

Without Suppression:	5-10ms
With Diode Suppression:	50-100ms
With Diode and Resistor (depending on value):	10-50ms

## Auxiliary Contact Switching Capacities (Resistive Load):

15 Amperes	at 24V DC
10 Amperes	at 48V DC
5 Amperes	at 96V DC

*All of the above figures should be used as a guide only.  
Some derating may be necessary according to type and application.*

"Albright is registered under BS EN ISO 14001 - Environmental Management System. Should you require information on the disposal of our products, please contact the Health, Safety & Environmental Manager of your Local Supplier for our Disposal Guidance Note"

## ALBRIGHT INTERNATIONAL LIMITED

*Albright*  
INTERNATIONAL

Evingar Trading Estate, Ardglen Road,  
Whitchurch, Hampshire, RG28 7BB, UK  
Tel: +44 (0)1256 893060  
Fax: +44 (0)1256 893562  
Direct Sales Tel: +44 (0)1256 890030  
Direct Sales Fax: +44 (0)1256 890043  
Email: sales@albrightinternational.com  
technical@albrightinternational.com  
Web Site: www.albrightinternational.com

