

Labels

LBL-MIC1

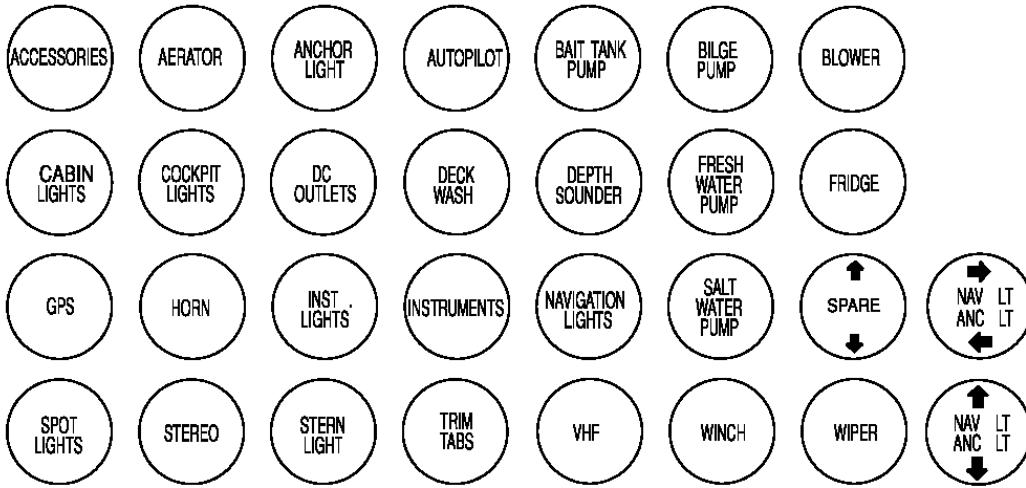

LBL-MIC2

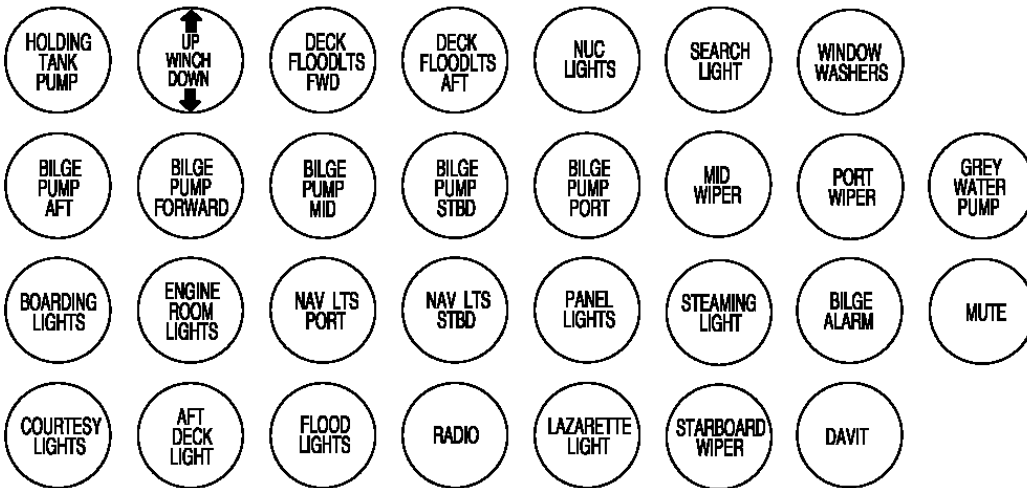

LBL-MICSYM

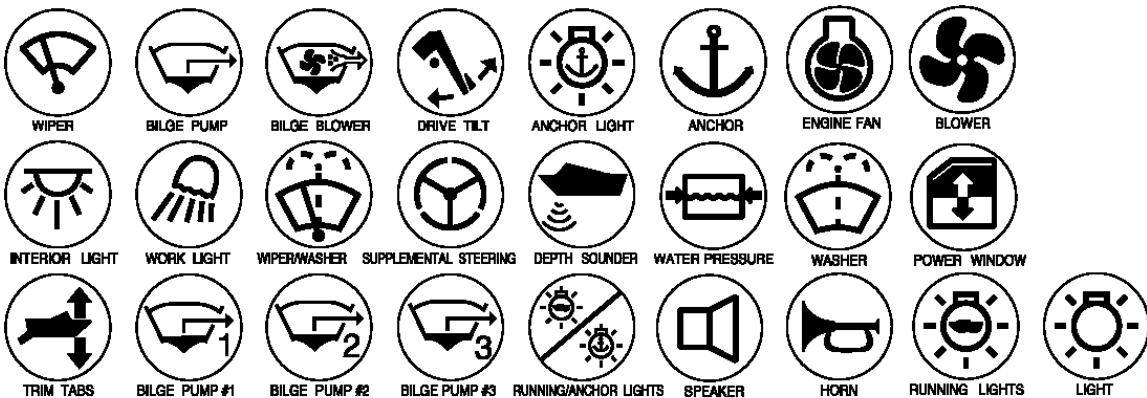

SPARE SWITCHES FOR CONTOUR GENERATION 2

SW-CG1	ON/OFF
SW-CG2	MOMENTARY ON/OFF
SW-CG3	ON/OFF/ON
SW-CG4	MOMENTARY ON/OFF/MOMENTARY ON
SW-CG5	ON/ON

INSTALLATION INSTRUCTIONS FOR CG2-4WF

1. Cut hole as per template. Use 4 screws supplied to retain the panel.
2. Connect the positive from the battery master switch into the connector supplied with the panel.
3. Fit panel backlight negative (black) to negative stud/buss bar (not supplied with panel).
4. Connect positive from appliance to the piggy back terminal on the selected switch and fit corresponding label (supplied in pack).
5. Fit negative from appliance to negative stud/buss bar.
7. To replace blown fuses, flip back cover of fuse holder as per drawing* and pull out old fuse. Push in new fuse and close cover. (Note maximum fuse rating is 15A).

NB. The fuse holders are supplied with 15A blade type fuses.

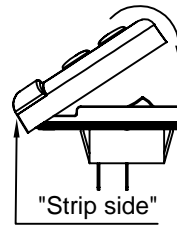

Fitting the lid to CG2 panels:
Make sure to fit from the "strip" side first and "roll" on

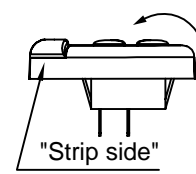

Removing the lid from CG2 panels:
(Unmounted): Hold panel securely in hand (by the switches) and "roll" cover off towards the strip side

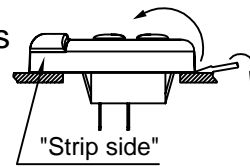

Removing the lid from CG2 panels:
(mounted): Carefully place lever under lid at opposite side to the strip. Gently apply pressure to lever.

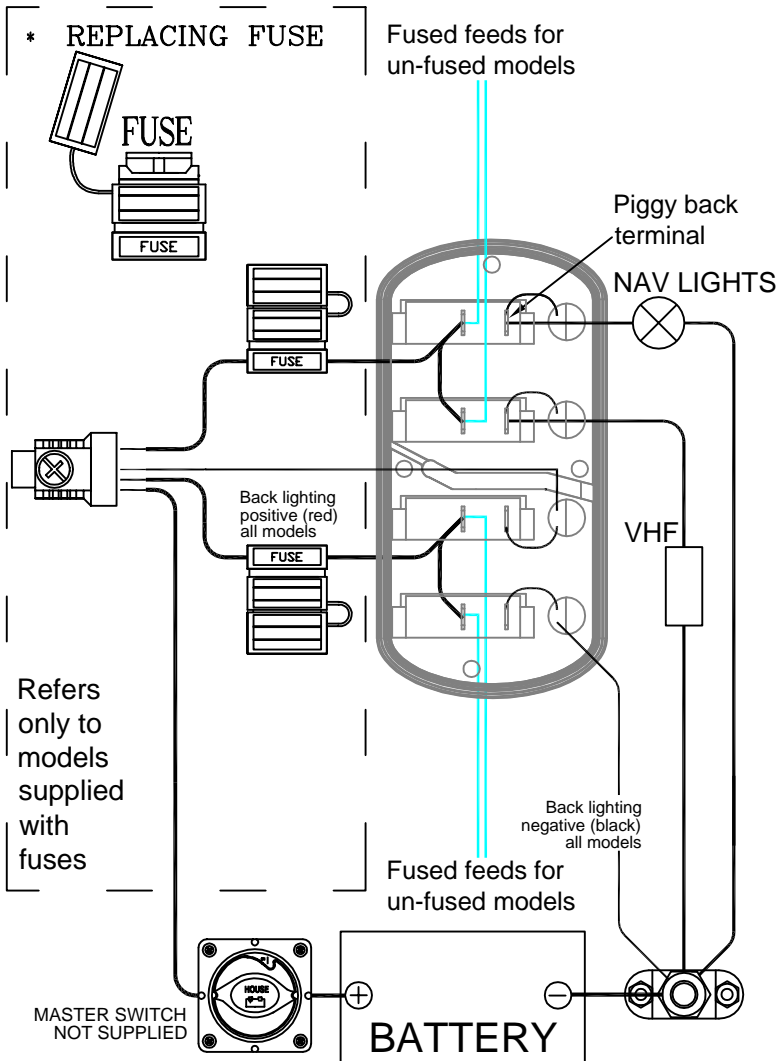

Refers only to models supplied with fuses

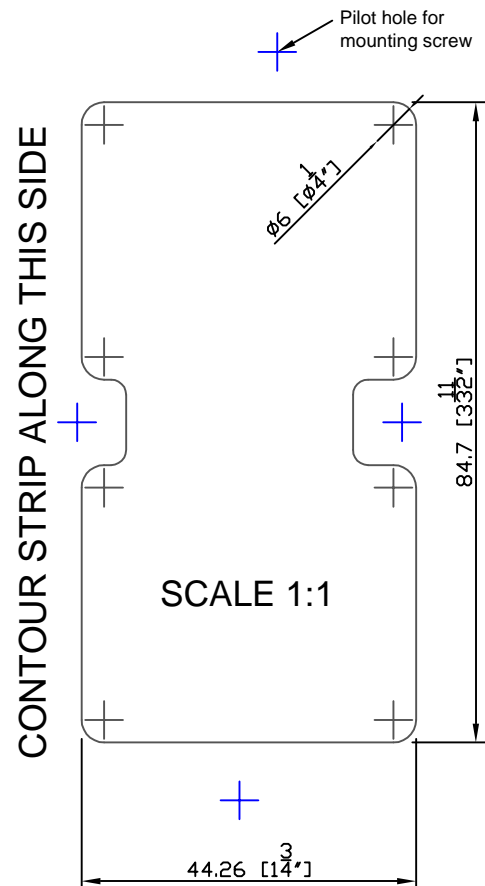

DATE	19/7/04	DWG No.	INST-CG2-4W		TITLE:
DRAWN	S PLAYER				CONTOUR GENERATION 2 INSTRUCTIONS
REV	DATE	DESCRIPTION	DRAWN	APPRVD	

BEP MARINE LTD.
13 Tarndale Grove
Albany
Auckland 1310 N.Z.
PH 09 415 7261 FAX 09 415 9327
www.bepmarine.com

